

SPM Pumps, Inc.
P.O. Box 32805
Palm Beach Gardens, FL 33420-2805



Phone 561-691-6947
Cell 561-352-0451
Email Support@SPMPumps.com

DREDGING UNIT WITH DREDGING PUMP AND EXCAVATOR

RELIABLE POWERFUL WEAR RESISTANT

SPECIFICATIONS

DREDGING PUMP

Discharge:	6 OR 8 INCH
Capacity:	1320 UP TO 1750 GPM
Pumping Head:	80 TO 100 FT
Speed:	950 UP TO 1150 RPM
Power:	50 UP TO 80 HP
Sand Production:	65 TO 100 CUBIC YARDS

EXCAVATOR

Power:	10 HP at 25 RPM up to 38 HP at 100RPM
Three Blade Cutter Head:	32 Inch Diameter
Six Teeth Esco Super V17VY	
Adjustable Speed:	25 up to 50 RPM for Cutting 50 up to 100 RPM for Mixing

HYDRAULICS

Dredging Pump:
 Fixed Displacement Axial Piston Motor, 6.6 Cubic Inch
 Required Flow: 27 up to 32 GPM at 4000 PSI

Excavator:
 Fixed Displacement Radial Piston Motor, 50 cubic Inch
 Required Flow: 0.2 Gals Per Revolution, 4000 PSI
 10 Gallons at 50 RPM

The Unit comes with a SUBMERSIBLE PRESSURE COMPENSATION ADJUSTABLE FLOW DIVIDER:
 Only three (3) Hydraulic umbilicals are needed to power the Hydraulic Dredging Pump and Excavator.

Power Hoses: 3/4 Inch Pressure and Return,
 1/2 Inch Drain

Recommended Flow and Pressure to Operate The Unit For Normal Dredging:

42GPM @ 4000PSI

Weight of Pump w/Exc:
 2420 Pounds

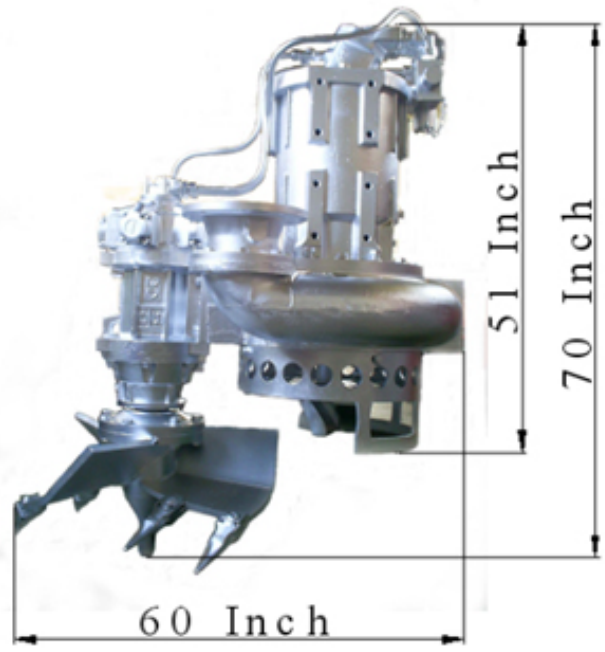

Representing:
 Hydraulic Dredging Systems, Inc
www.hdsbelgium.com